



3A,3/2



4A,5/2



4A,5/3



Specifications:

Type	3A110-M5, 06	3A120-M5, 06	3A210-06, 08	3A220-06, 08	3A310-08, 10	3A320-08, 10	3A410-15	3A420-15
Position number	2 Position 3 Way							
Port size(G)	M5, 1/8"		1/8" , 1/4"		1/4" , 3/8"		1/2"	
Applicable cylinder bores	φ 20~ φ 63mm				φ 63~ φ 100mm			
Fluid	Air							
Lubrication	Lubricated or not							
Operating pressure(Mpa)	0.15~0.8							
Temperature range	5~60°C							

How to order:

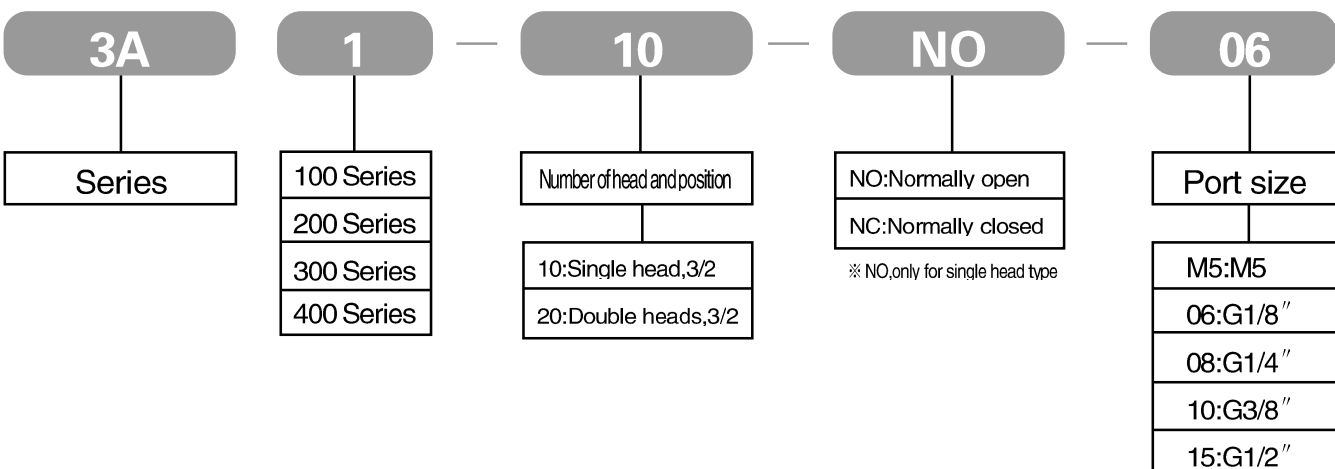

3A110-M5

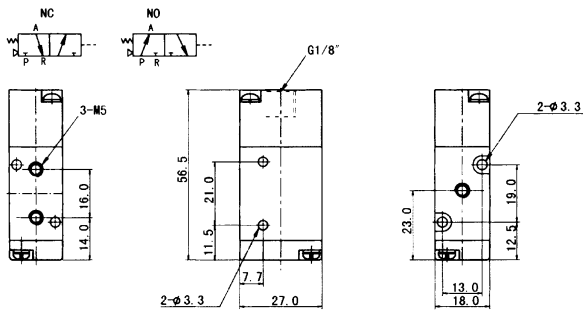

3A110-06

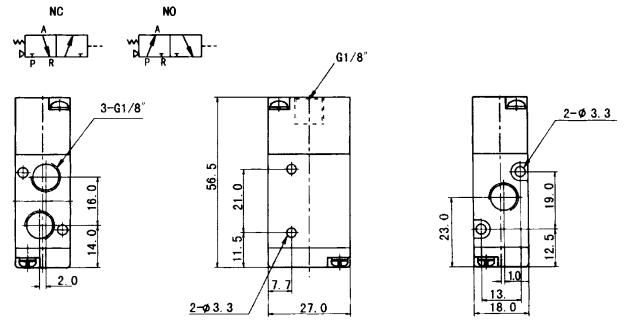

3A120-M5

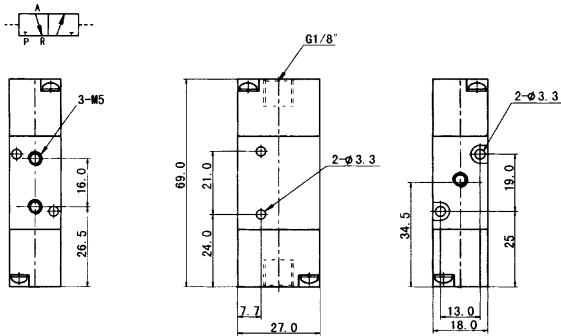

3A120-06

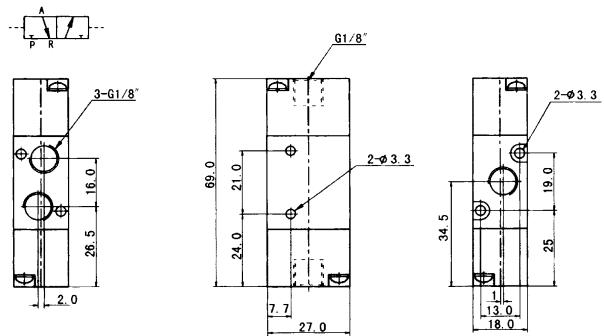

3A210-06

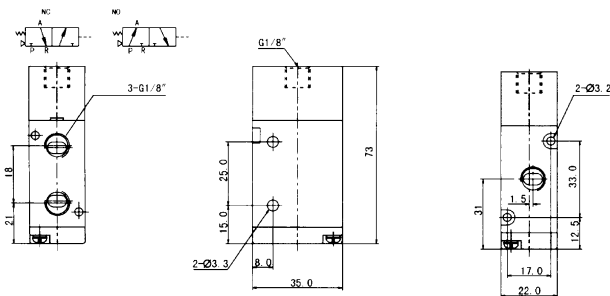

3A210-08

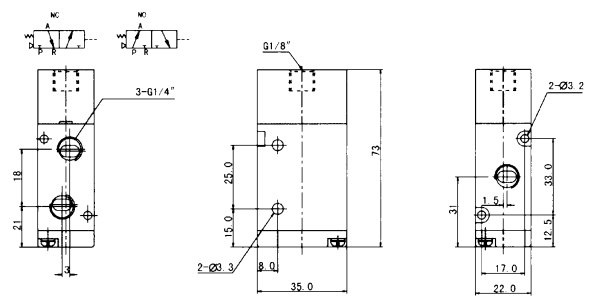

3A220-06

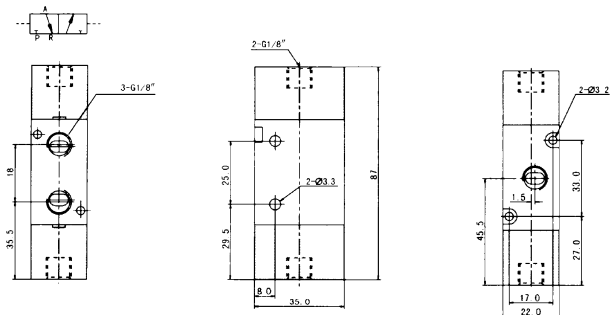

3A220-08

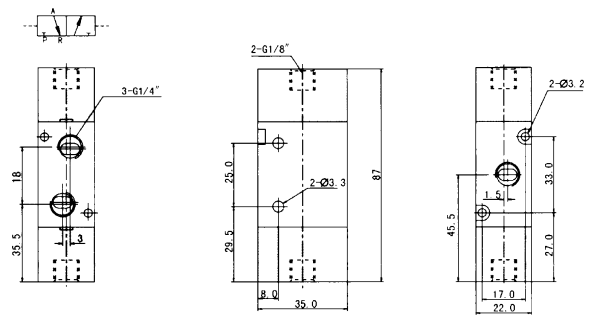

■ 3A310-08

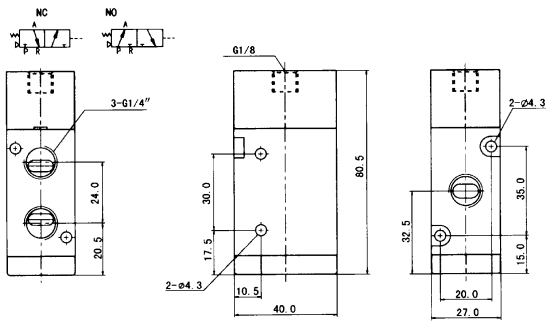

■ 3A310-10

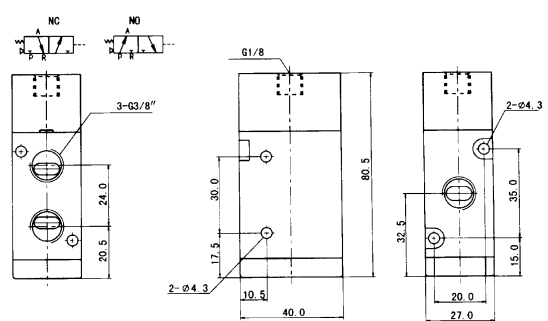

■ 3A320-08

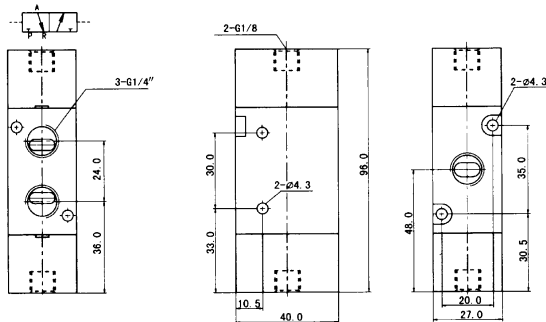

■ 3A320-10

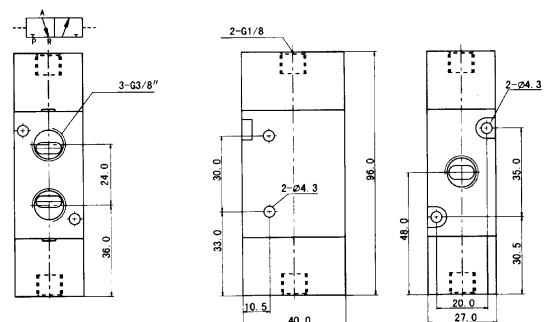

■ 3A410-15

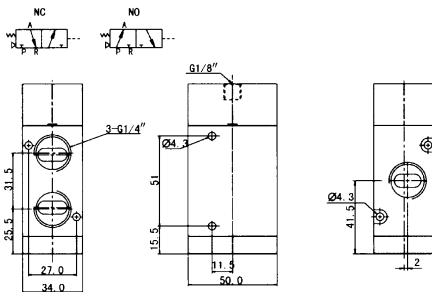

■ 3A420-15

